





AGENDA
OMAK CITY COUNCIL MEETING
Zoom Meeting
Monday, March 15, 2021 – 7:00 PM

- A. CALL TO ORDER
- B. GREETING
- C. CITIZEN COMMENTS
- D. CORRESPONDENCE AND MAYOR'S REPORT
 - 1. Proclamation – Michael W. Marshall
 - 2. Oaths of Office
 - 3. Appointment – Omak Planning Commission – John Schneider
- E. CONSENT AGENDA:
 - 1. Approval of minutes from March 1, 2021
 - 2. Approval of Claims
- F. NEW BUSINESS:
 - 1. Res. 18-2021 – Approving Purchase of Air Compressor – Papé Machinery, Inc. 
 - 2. Ord. 1903 – 1st Read - Amend 2021 Budget – C.E. - Appropriating Funds for Fire Truck Purchase 
 - 3. Ord. 1904 – Amend OMC Chapter 2.68 – City Office Hours - Office Hours Designation
- G. OTHER BUSINESS:
 - 1. Council Committee Reports
 - 2. Staff Reports

 **Action by City Council**

In accordance with the "Stay Home, Stay Healthy" order from Governor Inslee, our Council Meeting will be conducted using Zoom Meetings (information on next page).
If you need support, contact the City Clerk in advance of the meeting by calling 509-826-1170 or e-mail clerk@omakcity.com for assistance.

**The City of Omak is inviting you to a scheduled Zoom meeting
Monday, March 15th, 2021 @ 7:00pm**

Join Zoom Meeting

<https://us02web.zoom.us/j/86942614945?pwd=WHAvEdSNnhFcEprVEVFZ3h4OFZUZz09>

Meeting ID: 869 4261 4945

Passcode: 594249

One tap mobile

+12532158782,,86942614945#,,,,*594249# US (Tacoma)

+16699006833,,86942614945#,,,,*594249# US (San Jose)

Dial by your location

+1 253 215 8782 US (Tacoma)

+1 669 900 6833 US (San Jose)

+1 346 248 7799 US (Houston)

+1 929 205 6099 US (New York)

+1 301 715 8592 US (Washington DC)

+1 312 626 6799 US (Chicago)

Meeting ID: 869 4261 4945

Passcode: 594249

Find your local number: <https://us02web.zoom.us/j/86942614945?pwd=WHAvEdSNnhFcEprVEVFZ3h4OFZUZz09>

MEMORANDUM

To: Omak City Council
Cindy Gagné, Mayor

From: Ken Mears, Public Works Director

Date: March 15th, 2021

Subject: **Resolution No. 18-2021** Approving the Purchase of Air Compressor.

The attached **Resolution 18-2021, A Resolution of the Omak City Council Approving Purchase of Air Compressor**, is forwarded for your consideration.

The Public Works Department is requesting to replace the 1995 Sullair Air Compressor, which was scheduled to be replaced in 2020.

We receive three quotes and have reviewed them for accuracy and correctness. The lowest quote is from Pape Machinery, Inc., formerly "Washington Tractor," which includes the hose and jackhammer.

This Purchase total is \$22,454.93 and is covered in the 2021 Budget.

I support this Resolution and recommend its approval.

RESOLUTION NO. 18-2021

A Resolution of the Omak City Council Approving, Purchase of Air Compressor

WHEREAS, the Public Works Department needs to replace the 1995 Sullair Compressor; and

WHEREAS, this purchase exceeds five thousand dollars, requiring Omak City Council Approval for purchase; and

WHEREAS, three quotes were received for the needed equipment are attached; and

WHEREAS, Pape Machinery, Inc. has provided the lowest priced quote for the identified equipment.

NOW, THEREFORE BE IT RESOLVED by the City Council of the City of Omak, do hereby approve the purchase of the Air Compressor as attached in Exhibit "A," in the amount of \$ 22,454.93.

PASSED AND APPROVED this _____ day of _____, 2021.

SIGNED:

Cindy Gagné, Mayor

ATTEST:

Connie Thomas, City Clerk

APPROVED AS TO FORM:

Michael D. Howe, City Attorney

Purchasing Quote spread sheet

Item

AIR COMPRESSOR

vender

Air Electric

vender

Fastenal

vender

PAPE MACHINERY

vender

Quote

Freight

hose

jack hammer

Misc

Tax

\$	21,732.00

8.40% \$ 1,825.49

\$	24,219.30
\$	1,049.99
\$	2,122.62

\$	19,766.88
\$	66.00
\$	882.00
\$	1,740.05

\$	-

Total

\$ 23,557.49

\$ 27,391.91

\$ 22,454.93

\$ -

Quote Summary

Prepared For:
 City Of Omak
 WA

Prepared By:
 Kevin Oyler
 Pape Machinery, Inc.
 1 Patrol Street
 Okanogan, WA 98840
 Phone: 509-422-3030
 koyler@papemachinery.com

This sale is subject to Papé's Terms and Conditions of Sale effective on the date hereof, which are incorporated in full by this reference. The Terms and Conditions of Sale are available at www.pape.com/terms, and will also be sent by mail or e-mail to the purchaser upon request.

Quote Id: 23544574
Created On: 25 January 2021
Last Modified On: 05 February 2021
Expiration Date: 01 February 2021

Equipment Summary	Selling Price		Qty		Extended
2020 CHICAGO PNEUMATIC 185cfc	\$ 19,766.88	X	1	=	\$ 19,766.88
2020 CHICAGO PNEUMATIC 90# hammer	\$ 882.00	X	1	=	\$ 882.00
2020 CHICAGO PNEUMATIC air hose 50 foot	\$ 66.00	X	1	=	\$ 66.00
Equipment Total					\$ 20,714.88

Quote Summary

Equipment Total	\$ 20,714.88
SubTotal	\$ 20,714.88
Sales Tax - (8.40%)	\$ 1,740.05
Total	\$ 22,454.93
Down Payment	(0.00)
Rental Applied	(0.00)
Balance Due	\$ 22,454.93

Salesperson : X _____

Accepted By : X _____



JOHN DEERE

Selling Equipment



Quote Id: 23544574

2020 CHICAGO PNEUMATIC 185cfc				
Hours:		0		
Stock Number:				
				Selling Price
				\$ 19,766.88
Code	Description	Qty	Unit	Extended
air	185 cfm towable air compressor	1	\$ 19,766.88	\$ 19,766.88
Suggested Price				\$ 19,766.88
Customer Discounts				
Customer Discounts Total			\$ 0.00	\$ 0.00
Total Selling Price				\$ 19,766.88

2020 CHICAGO PNEUMATIC 90# hammer				
Hours:		0		
Stock Number:				
				Selling Price
				\$ 882.00
Code	Description	Qty	Unit	Extended
air	90 pound air hammer	1	\$ 882.00	\$ 882.00
Suggested Price				\$ 882.00
Customer Discounts				
Customer Discounts Total			\$ 0.00	\$ 0.00
Total Selling Price				\$ 882.00

2020 CHICAGO PNEUMATIC air hose 50 foot				
Hours:		0		
Stock Number:				
				Selling Price
				\$ 66.00
Code	Description	Qty	Unit	Extended
air	3/4x50 hose 200 psi	1	\$ 66.00	\$ 66.00
Suggested Price				\$ 66.00
Customer Discounts				
Customer Discounts Total			\$ 0.00	\$ 0.00
Total Selling Price				\$ 66.00



JOHN DEERE

Selling Equipment



Quote Id: 23544574

TERMS AND CONDITIONS OF SALE

TERMS AND CONDITIONS OF SALE: Sales Orders are based on the terms and conditions stated herein. Unless otherwise provided on the face hereof, offers are good for acceptance for a period of 30 days from the date hereof. An order by the Buyer shall constitute an acceptance of the terms and conditions herein proposed. If, and only if, no offer of sale is issued by Seller, then the invoice shall be deemed: an acceptance of the Buyer's order; a written confirmation; and a final, complete, and exclusive written expression of the agreement between Seller and Buyer. Buyer is hereby notified that additional or different terms from those contained herein are objectionable.

1. Taxes. Buyer shall pay all local, state, and federal taxes arising from or related to any sale or lease to which this document relates, except for taxes upon or measured by net income of Seller.

2. Delivery. Stated or promised delivery dates are estimates only based upon Seller's best judgment and Seller shall not be responsible for deliveries later than promised regardless of the cause. Delivery periods are projected from the date of receipt of any order by Seller, but if equipment to be furnished by Seller is to be manufactured specifically to fill a particular order, delivery periods will be projected from the date of Seller's receipt of complete manufacturing information. If the furnishing of equipment on orders accepted by Seller is hindered or prevented by public authority or by the existence of war or other contingencies, including, but not limited to, shortage of materials, fires, labor difficulties, accidents, delays in manufacture or transportation, acts of God, embargoes, inability to ship, inability to insure against war risks or substantially increased prices or freight rates, or other causes beyond Seller's control, the obligation to fill or complete such orders shall be excused by Seller's option.

3. Transportation and Claims. Prices quoted are net F.O.B. point designated in writing by Seller. When no F.O.B. point is designated in writing by Seller, prices for new equipment shall be deemed to be net F.O.B. point of manufacture and prices for all other equipment shall be deemed to be F.O.B. Seller's place of business at which the order for the equipment is accepted. When transportation is allowed, the price charged will be adjusted to reflect the lowest transportation rates in effect at the time of shipment even though such rates may differ from those quoted by Seller. Seller's responsibility for the equipment shall cease and all risk of loss shall become the Buyer's upon delivery of the equipment to the first carrier for shipment to the Buyer or his consignee, even though such delivery shall be made prior to the arrival of the equipment at the F.O.B. point designated, and any and all claims for shortages, deliveries, damages or non-delivery must be made by the Buyer or his consignee to the carrier. Seller shall in no event be responsible for shortages in shipments unless notice of such shortage is given in writing to Seller within 15 days after receipt of shipment.

4. Payment and Security. Buyer agrees to pay in full for the equipment at time of delivery. Buyer agrees to pay the late charge on any past due balance at the rate of 18% per annum. The signator warrants that he/she has authority to execute this order on behalf of any party for whom he/she signs, and that such party has the power to enter into this agreement and perform its terms. As security for all of Buyer's obligations to Seller, Buyer grants to Seller a security interest in the equipment and authorizes Seller to file all documents necessary to perfect Seller's security interest. The security interest granted hereunder is in addition to any other rights available to Seller, and Seller shall have all of the rights and remedies available to a secured party under the Uniform Commercial Code, all of which are cumulative. Throughout the duration of Seller's security interest, Buyer shall keep the equipment fully insured against theft and loss or damage by fire and other casualty as Seller may from time to time require in accordance with such terms as Seller may require.

5. Buyer to Furnish. Performance by Seller is subject to the Buyer furnishing a satisfactory credit rating certificate, letter of credit, evidence of financing, or any other similar papers necessary for the satisfactory completion of such order.

6. Laws Governing. All orders will be governed by the laws of the State of Oregon.

7. Assignment. The right to any monies due or to become due hereunder may be assigned by Seller, and Buyer, upon receiving notice of such assignment, shall make payment as directed.

8. Limitations of Warranties. If "NEW" warranty is indicated on the reverse side or if new equipment is purchased hereunder, all warranties are strictly given only by the manufacturer. Copies of manufacturer's warranty can be obtained from Seller. If "USED" warranty is indicated on the reverse side, Seller hereby warrants to Buyer that the equipment or components thereof designated on the reverse side, shall be free under normal use and service from defects in material and workmanship for the period shown, commencing on the date of delivery. Buyer's exclusive remedy for breach of the limited warranty shall be the repair or replacement of the warranted equipment without charge to Buyer when returned at Buyer's expense to the Seller's facility where the equipment was purchased, with proof of purchase. Buyer must give notice of any warranty claim not later than 7 days after the expiration of the warranty period and must return the equipment to Seller for repair or replacement no later than 30 days after expiration of the warranty period. Any action against Seller for breach of the limited warranty must be commenced within one year after the date of delivery of the equipment. Seller's warranty does not extend to any defect, claim, or damage attributable to the failure to operate and/or maintain the equipment in accordance with the manufacturer's specifications, or due to the failure to operate or maintain the equipment in accordance with any recommendations of Seller. If "AS IS" is indicated on the reverse side, no warranty of any kind is being given and the equipment is being sold with all faults. THE WARRANTIES IN THIS PARAGRAPH AND ON THE REVERSE SIDE ARE THE EXCLUSIVE WARRANTIES GIVEN BY SELLER AND SUPERSEDE ANY PRIOR, CONTRARY, OR ADDITIONAL REPRESENTATIONS, WHETHER ORAL OR WRITTEN. SELLER HEREBY DISCLAIMS AND EXCLUDES ALL OTHER WARRANTIES, WHETHER EXPRESS, IMPLIED, OR STATUTORY, INCLUDING THE IMPLIED WARRANTIES OF MERCHANTABILITY OR FITNESS FOR A PARTICULAR PURPOSE, AND ANY IMPLIED WARRANTIES OTHERWISE ARISING FROM COURSE OF DEALING OR USAGE OF TRADE. SELLER SHALL NOT BE LIABLE FOR ANY LOSS, INJURY, OR DAMAGE TO PERSONS OR PROPERTY RESULTING FROM THE FAILURE OR DEFECTIVE OPERATION OF THE EQUIPMENT; NOR WILL SELLER BE LIABLE FOR DIRECT, INDIRECT, SPECIAL, INCIDENTAL, OR CONSEQUENTIAL DAMAGES OF ANY KIND SUSTAINED FROM ANY CAUSE. This exclusion applies regardless of whether such damages are sought for breach of warranty, breach of contract, negligence, or strict liability in tort or under any other legal theory.

9. Rental Purchase Option. If rental purchase option (RPO) is granted in any addendum, the purchase price shall be tendered to Seller coincidentally with the exercise of the purchase option provided that Buyer is not then in default in performing all of the terms and conditions of lease with Seller.

10. Notice. This paragraph shall serve as notice that The Papé Group, Inc. has assigned its rights to sell its rental equipment (as may be described in this sales order) and its rights to sales proceeds (including "trade-in assets" related thereto) to North Star Deferred Exchange as part of an IRC Sec. 1031 exchange.

11. Attorneys Fees. In the event suit or action is instituted against Buyer on account of or in connection with or based upon the terms hereof, the Buyer agrees to pay, in addition to the costs and disbursements provided by law, such sum as the court may adjudge reasonable attorney's fees in both the trial and appellate courts, or in connection with any bankruptcy proceeding.

12. Entire Agreement. The foregoing and any addendum shall constitute the complete and exclusive agreement between the parties, and it is expressly understood and agreed that no promises, provisions, terms, warranties, conditions, guarantees, or obligations whatsoever, either expressed or implied, other than as herein set forth or provided for shall be binding on either party. Each party may transmit its signature by facsimile to the other party and such facsimile signatures shall have the same force and effect as an original signature.



JDLink Account Setup Form

THIS FORM MUST BE TURNED IN TO REGION SALES ADMINISTRATOR AT THE TIME OF SETTLEMENT.

Territory Manager

CSA

Machine Serial Number

Company/Customer Name

Business Address

Phone

JDLink Admin Information

First Name

Last Name

E-mail Address

Ask customer if they have an existing MyJohnDeere/JDLink Account

Sales Admin Initials

MJD/JDLink Username

Opt Out of Active Data Monitoring

Terminate the collection or sharing of JDLink data for use in monitoring or diagnosing or providing service solutions.

By signing you agree to cancel subscriptions, disengage the data collection modules, and are deactivating your machine permanently.

Signature

Date

SALES ADMINISTRATOR MUST SUBMIT COMPLETED FORM WITH SETTLEMENT PAPERWORK.

TERMS AND CONDITIONS OF SALE

TERMS AND CONDITIONS OF SALE: Sales Orders are based on the terms and conditions stated herein. Unless otherwise provided on the face hereof, offers are good for acceptance for a period of 30 days from the date hereof. An order by the Buyer shall constitute an acceptance of the terms and conditions herein proposed. If, and only if, no offer of sale is issued by Seller, then the invoice shall be deemed: an acceptance of the Buyer's order; a written confirmation; and a final, complete, and exclusive written expression of the agreement between Seller and Buyer. Buyer is hereby notified that additional or different terms from those contained herein are objectionable.

1. Taxes. Buyer shall pay all local, state, and federal taxes arising from or related to any sale or lease to which this document relates, except for taxes upon or measured by net income of Seller.

2. Delivery. Stated or promised delivery dates are estimates only based upon Seller's best judgment and Seller shall not be responsible for deliveries later than promised regardless of the cause. Delivery periods are projected from the date of receipt of any order by Seller, but if equipment to be furnished by Seller is to be manufactured specifically to fill a particular order, delivery periods will be projected from the date of Seller's receipt of complete manufacturing information. If the furnishing of equipment on orders accepted by Seller is hindered or prevented by public authority or by the existence of war or other contingencies, including, but not limited to, shortage of materials, fires, labor difficulties, accidents, delays in manufacture or transportation, acts of God, embargoes, inability to ship, inability to insure against war risks or substantially increased prices or freight rates, or other causes beyond Seller's control, the obligation to fill or complete such orders shall be excused by Seller's option.

3. Transportation and Claims. Prices quoted are net F.O.B. point designated in writing by Seller. When no F.O.B. point is designated in writing by Seller, prices for new equipment shall be deemed to be net F.O.B. point of manufacture and prices for all other equipment shall be deemed to be F.O.B. Seller's place of business at which the order for the equipment is accepted. When transportation is allowed, the price charged will be adjusted to reflect the lowest transportation rates in effect at the time of shipment even though such rates may differ from those quoted by Seller. Seller's responsibility for the equipment shall cease and all risk of loss shall become the Buyer's upon delivery of the equipment to the first carrier for shipment to the Buyer or his consignee, even though such delivery shall be made prior to the arrival of the equipment at the F.O.B. point designated, and any and all claims for shortages, deliveries, damages or non-delivery must be made by the Buyer or his consignee to the carrier. Seller shall in no event be responsible for shortages in shipments unless notice of such shortage is given in writing to Seller within 15 days after receipt of shipment.

4. Payment and Security. Buyer agrees to pay in full for the equipment at time of delivery. Buyer agrees to pay the late charge on any past due balance at the rate of 18% per annum. The signator warrants that he/she has authority to execute this order on behalf of any party for whom he/she signs, and that such party has the power to enter into this agreement and perform its terms. As security for all of Buyer's obligations to Seller, Buyer grants to Seller a security interest in the equipment and authorizes Seller to file all documents necessary to perfect Seller's security interest. The security interest granted hereunder is in addition to any other rights available to Seller, and Seller shall have all of the rights and remedies available to a secured party under the Uniform Commercial Code, all of which are cumulative. Throughout the duration of Seller's security interest. Buyer shall keep the equipment fully insured against theft and loss or damage by fire and other casualty as Seller may from time to time require in accordance with such terms as Seller may require.

5. Buyer to Furnish. Performance by Seller is subject to the Buyer furnishing a satisfactory credit rating certificate, letter of credit, evidence of financing, or any other similar papers necessary for the satisfactory completion of such order.

6. Laws Governing. All orders will be governed by the laws of the State of Oregon.

7. Assignment. The right to any monies due or to become due hereunder may be assigned by Seller, and Buyer, upon receiving notice of such assignment, shall make payment as directed.

8. Limitations of Warranties. If "NEW" warranty is indicated on the reverse side or if new equipment is purchased hereunder, all warranties are strictly given only by the manufacturer. Copies of manufacturer's warranty can be obtained from Seller. If "USED" warranty is indicated on the reverse side. Seller hereby warrants to Buyer that the equipment or components thereof designated on the reverse side, shall be free under normal use and service from defects in material and workmanship for the period shown, commencing on the date of delivery. Buyer's exclusive remedy for breach of the limited warranty shall be the repair or replacement of the warranted equipment without charge to Buyer when returned at Buyer's expense to the Seller's facility where the equipment was purchased, with proof of purchase. Buyer must give notice of any warranty claim not later than 7 days after the expiration of the warranty period and must return the equipment to Seller for repair or replacement no later than 30 days after expiration of the warranty period. Any action against Seller for breach of the limited warranty must be commenced within one year after the date of delivery of the equipment. Seller's warranty does not extend to any defect, claim, or damage attributable to the failure to operate and/or maintain the equipment in accordance with the manufacturer's specifications, or due to the failure to operate or maintain the equipment in accordance with any recommendations of Seller. If "AS IS" is indicated on the reverse side, no warranty of any kind is being given and the equipment is being sold with all faults. **THE WARRANTIES IN THIS PARAGRAPH AND ON THE REVERSE SIDE ARE THE EXCLUSIVE WARRANTIES GIVEN BY SELLER AND SUPERSEDE ANY PRIOR, CONTRARY, OR ADDITIONAL REPRESENTATIONS, WHETHER ORAL OR WRITTEN. SELLER HEREBY DISCLAIMS AND EXCLUDES ALL OTHER WARRANTIES, WHETHER EXPRESS, IMPLIED, OR STATUTORY, INCLUDING THE IMPLIED WARRANTIES OF MERCHANTABILITY OR FITNESS FOR A PARTICULAR PURPOSE, AND ANY IMPLIED WARRANTIES OTHERWISE ARISING FROM COURSE OF DEALING OR USAGE OF TRADE. SELLER SHALL NOT BE LIABLE FOR ANY LOSS, INJURY, OR DAMAGE TO PERSONS OR PROPERTY RESULTING FROM THE FAILURE OR DEFECTIVE OPERATION OF THE EQUIPMENT; NOR WILL SELLER BE LIABLE FOR DIRECT, INDIRECT, SPECIAL, INCIDENTAL, OR CONSEQUENTIAL DAMAGES OF ANY KIND SUSTAINED FROM ANY CAUSE.** This exclusion applies regardless of whether such damages are sought for breach of warranty, breach of contract, negligence, or strict liability in tort or under any other legal theory.

9. Rental Purchase Option. If rental purchase option (RPO) is granted in any addendum, the purchase price shall be tendered to Seller coincidentally with the exercise of the purchase option provided that Buyer is not then in default in performing all of the terms and conditions of lease with Seller.

10. Notice. This paragraph shall serve as notice that The Papé Group, Inc. has assigned its rights to sell its rental equipment (as may be described in this sales order) and its rights to sales proceeds (including "trade-in assets" related thereto) to North Star Deferred Exchange as part of an IRC Sec. 1031 exchange.

11. Attorneys Fees. In the event suit or action is instituted against Buyer on account of or in connection with or based upon the terms hereof, the Buyer agrees to pay, in addition to the costs and disbursements provided by law, such sum as the court may adjudge reasonable attorney's fees in both the trial and appellate courts, or in connection with any bankruptcy proceeding.

12. Entire Agreement. The foregoing and any addendum shall constitute the complete and exclusive agreement between the parties, and it is expressly understood and agreed that no promises, provisions, terms, warranties, conditions, guarantees, or obligations whatsoever, either expressed or implied, other than as herein set forth or provided for shall be binding on either party. Each party may transmit its signature by facsimile to the other party and such facsimile signatures shall have the same force and effect as an original signature.

Notice: When operated in California, any off-road diesel vehicle may be subject to the California Air Resources Board In-Use Off-road Diesel Vehicle Regulation. It therefore could be subject to retrofit or accelerated turnover requirements to reduce emissions of air pollutants. For more information, please visit the California Air Resources Board website at:

<http://www.arb.ca.gov/msprog/ordiesel/ordiesel.htm>.

CPS 185 Kubota USA

Portable compressor



Standard Scope of Supply

The Chicago Pneumatic **CPS 185 Kubota** is a single-stage oil-injected rotary screw type air compressor, powered by a liquid-cooled, three cylinder diesel engine.

The unit consists of an air end, diesel engine, cooling circuit, air/oil separation and control systems - all enclosed within a sound dampened Redrock™ polyethylene shell.

Unique features – 110% fluid containment, internal toolbox, external lifting eye, new easy to use controller XC1004

Available Models

CPS 185

single stage - 100 psi – Kubota engine

Standard Features

- Latest screw technology
- 110% Spillage Free Containment Frame
- Xc1004 controller
- Heavy Duty Single Axle Trailer w/ 15" tires
- Internal tool box
- Spin on type compressor oil separator
- Redrock™ Enclosure
- External lifting eye

Benefits

- 189 CFM free air delivery @ 2.37 Gal/hr (8.97 L/hr)
- Protects environment from spill/ leaks, avoids costly clean up
- Easy to use, one controller to regulate the entire machine
- Well balanced for safer towing or moving around site
- High ground clearance for rough site and road conditions
- Internal Tool Box – Fits 90 lb hammer fit all you need inside the lockable compressor
- Less than one hour service with no special tools required
- Heavy double wall polyethylene enclosure
- Dent and UV Resistant
- Keeps looking new for longer and adds to resale value
- Easy access for getting on/off site

Optional Features

- Extended Draw bar with hose reel
- Lubricator
- Safety cartridge
- Undercarriage variants and add-ons
- OSHA valve
- FleetLink
- Battery disconnect
- Cold weather package

Benefits

- Keeps all of the customer's hoses in the same place, great for municipal bids. It comes as 50' or 100' Single Hose Reel or Dual Hose Reel
- Shipped Loose
- To offer extra filtration, safer operations and you it gives the option to change the air filter without stopping the machine
- Electric brakes, Hydraulic brakes, jockey wheel, frame D Rings, support mount, several types of loose ball couplings (2 5/16", 2" and 2" bulldog), 6 way trailer end.
- OSHA compressed air safety shut-off valves immediately shut off the air supply should the volume of air flowing through the valve exceed a preset value. (For example: when an air hose breaks)
- FleetLink is an intelligent telematics system that helps optimize fleet usage; reduce maintenance cost, ultimately saving time and money. It allows you to manage your machines conveniently wherever you are, always having the latest fleet information at hand.
- Prevents battery power loss when machinery not being used
- Feature required for starting at -13°F and cold weather operations. Includes: 120V block heater, synthetic compressor oil, closed circuit breather kit (CCVI), coolant, battery disconnect). With this package, the compressor service interval increases from 1000 hours to 1500 hours or 2 years.

CPS 185 Kubota – Product Reference

Technical Data

Compressor	Units	CPS 185 KD8 T4F
Actual free air delivery ¹ (FAD)	cfm	189
Normal effective working pressure	Psi	100
Maximum unloading pressure	Psi	125
Minimum working pressure	Psi	58
Max. sound pressure level @ 23' (7m) at normal working speed & pressure ²	dB(a)	76
Compression Stages		1
Air Receiver Capacity	US Gal (L)	4.76 (18.0)
Compressor oil capacity	US Gal (L)	2.5 (9.7)
Approximate air outlet temperature	°F (°C)	200 (93)
Air Compressor outlets		2 x ¾"
Max. ambient temperature (at sea level) ³	°F (°C)	122 (50)
Maximum altitude	ft (m)	9842 (3000)
Minimum starting temperature (without cold weather options)	°F (°C)	14 (-10)
Minimum starting temperature (with cold weather options)	°F (°C)	-13 (-25)
Engine	Kubota	D1803-T
Emissions Regulation	US EPA	Tier 4 Final
US EPA Engine Family		KKBXL01.8EMD
Output at rated speed (2700 rpm) ⁴	HP	49.6
Number of cylinders		3
Aspiration		Turbocharged
Displacement	cu in (L)	111.4 (1.82)
Engine speed (Unloaded)	rpm	1800
Engine speed (Maximum loaded)	rpm	2900
Engine oil capacity	US Gal (L)	1.62 (6.1)
Engine coolant capacity	US Gal (L)	2.6 (9.9)
Fuel tank capacity	US Gal (L)	27 (102)
Fuel consumption at 100% load	Gal/Hr (L/Hr)	2.37 (8.97)
Fuel consumption at 75% load	Gal/Hr (L/Hr)	2.15 (8.14)
Fuel consumption at 50% load	Gal/Hr (L/Hr)	1.69 (6.40)
Fuel consumption at 25% load	Gal/Hr (L/Hr)	1.35 (5.11)
Fuel consumption at 0% load	Gal/Hr (L/Hr)	1.13 (4.28)
Electrical System (Negative Ground)	V	12
Battery Capacity (Cold Cranking Amps ⁵)	A	725

¹ According to ISO 1217 ed.3 1996 annex D

² Measured in accordance with ISO 2151 under free field conditions @ 7m distance

³ Consult Chicago Pneumatic for proper de-rating instructions for operation beyond ambient limitations

⁴ Horsepower limited by Engine ECU

⁵ According to DIN 72311

Dimensions

Trailer mounted - Redrock™ Version

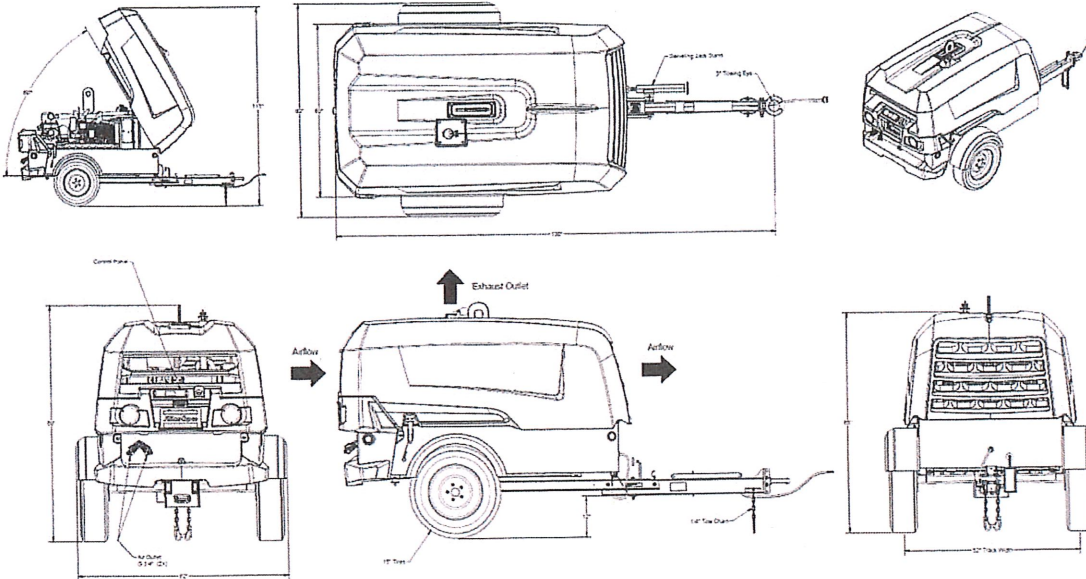

Weight (Wet - Ready-to-operate)

		CPS 185 Kubota
Trailer mounted	lb (Kg)	> 2100 (952)

Dimensions

		CPS 185 Kubota
Trailer mounted Inches (m)	L x W x H	130 (3.3) x 62 (1.57) x 69 (1.75)

ALTITUDE UNIT PERFORMANCE CURVE

Maximum allowable working pressure as a function of altitude and ambient temperature

Unit Name:

CPS 185

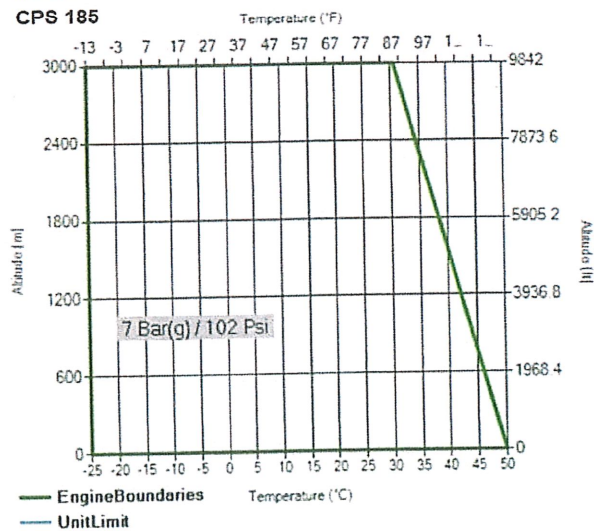

Graph represents working conditions, for starting conditions please contact your Chicago Pneumatic contact

Principle Data

Compressor Element

The CPS 185 compressor utilizes the new C-90 element that is driven from the diesel engine with coupling. Our new element brings even more flow with less fuel consumption.

Inlet air is filtered through a heavy-duty two-stage air filter.

Air/Oil Separator

Air and oil separation is achieved through a centrifugal compressor oil separator with a spin on type filter element for easy maintenance. Separators are ASME/CRN approved versions and are stamped accordingly.

The separator is equipped with a sealed high-pressure safety relief valve, sonic nozzle, automatic blow-down valve, and pressure regulator.

Easy to service, just one hour service, no special tools and up to 1500 hour / 2 years compressor service interval.

Air/Oil Separator Tank:

Volume	4.76 US Gal / 18 L
Certifications	ASME / CRN
MAWP	261psi @ 248°F

Cooling System

The cooling system consists of integrated side-by-side aluminum oil cooler with axial fan to ensure optimum cooling. A guard for operator safety protects the fan. There is an access port on both sides of the fan box for easy cleaning

The cooling system is suitably designed for continuous operation in ambient conditions up to 122°F, with canopy door closed..

Compressor Regulating System

The compressor regulating system consists of air receiver/oil separator, compressor element, blow down valve and pressure safety valve.

Economic power consumption is assured by the fully automatic 100% step-less speed regulator that adapts engine speed to air demand.

Discharge Outlets

Compressed air is available from 2 x 3/4" outlet valves, with claw type (Chicago) coupling.

Storage Compartment

The compressor has a built in open top tool box compartment. Tool box dimension is: 33.8"L x 7.4" W x 10" H.

Safety Features

The compressor has many safety features: Pressure safety valve, emergency shut down button, low fuel shut down, high temperature engine coolant, high temperature compressor oil and engine oil pressure

Engine

Kubota D1803-T

Kubota D1803 Tier 4 Final, turbocharged, three-cylinder, liquid-cooled diesel engine provides ample power to operate the compressor continuously at full-load.

Meets all US EPA and Environment Canada exhaust legislations with Tier 4 Final compliance. The US EPA engine family is "EKBXL02.4END". The engine utilizes a DOC to meet Tier 4 Final emissions. All functionality of the engine and exhaust after treatment are controlled automatically on the XC1004 controller.

Engine output at rated speed, in accordance to SAE Standard, is 49hp at 2700 rpm, as limited by the engine ECU.

The engine has the capability to start the compressor to 14°F (-10°C) with standard glow-plug aid. Cold start options are available for up to -13°F (-25°C).

The 27 Gal (102L) fuel tank is sufficiently sized to operate the unit for 11 hours at full-load condition.

Electrical System

The **CPS 185 Kubota** is equipped with a 12 Volt negative ground electrical starting system.

Instrumentation

The instrument control panel is located on the back, of the compressor canopy with easy access.

Standard instrument package includes an operating pressure gauge, and fully diagnostic ECU controller with large 3.5" display. The intuitive XC1004 controller is easy to operate with all functions conveniently at your fingertips. The controller also manages the engine ECU operating system, and a number of safety warnings and shut downs on various parameters (listed below).

XC1004 Controller Functionality:

- Displayed while running
 - Hours
 - Fuel level
 - RPM
 - Outlet pressure
- Compressor measurements displayed
 - Running hours
 - Fuel level
 - Battery voltage
 - Running hours
 - Regulating pressure
 - Minor and major service counters in hours and days
 - Compressor element temperature
- Warnings and Shutdowns
 - High temperature engine coolant
 - High temperature compressor oil
 - Engine oil pressure
 - Low fuel level
- Settings
 - Reset service timers
 - Diagnostics for engine ECU
 - Unit of measure changes
- Operational Buttons
 - Start and stop of the unit
 - View measurements, settings and alarms
 - Graphical representations of the alarms
- Engine measurements displayed
 - Current fuel level
 - Engine coolant temperature
 - Engine oil pressure
 - Engine RPM
- Alarms
 - View current & historical alarms present
 - DM1: View current engine codes (SPN/FMI)

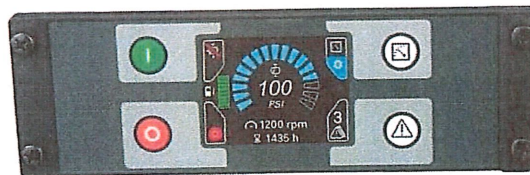

Bodywork

The compressor is delivered in the Redrock™ version.

Redrock™: Our Redrock™ version comes standard with dual wall, Polyethylene material providing superior corrosion, and UV protection against fading and discoloration. As well as unmatched dent and damage resistance. The canopy is sound attenuated to meet the most current legal noise requirements. A clamshell style hood offers easy service access to all components.

Undercarriage

The **CPS 185 Kubota** compressor is available with undercarriage alternatives, providing utmost flexibility in installation or towing requirements.

- Single axle trailer setup with:
 - US DOT/Federal MVSS 49CFR571 approved light package and 4 way trailer plug
 - Adjustable height pintle hitch (3" lunette)
 - External lifting eye
 - 15" Rims w/ ST205/75D15 Tires for trailer use
 - Trailer brakes not standard (can be added as option)
 - Heavy Duty torsion axle rated at 2,500lbs
 - Safety chains
 - Screw jack leveling
 - Single point lifting structure

- Undercarriage options
 - Loose Ball Coupling 2 5/6"
 - Loose Ball Coupling 2"
 - Loose Ball Coupler 2" Bulldog
 - Electric Brake
 - Hydraulic Brake

Manufacturing & Environmental Standards

The **CPS 185 Kubota** is manufactured following stringent ISO 9001 regulations, and by a fully implemented Environmental Management System fulfilling ISO 14001 requirements.

Attention has been given to ensure minimum negative impact to the environment.

The **CPS 185 Kubota** meets all current US EPA, CARB and Environment Canada exhaust and noise emission directives.



Supplied Documentation

The unit is delivered with documentation regarding:

- Hard copies of the Chicago Pneumatic Operators Safety and Instruction Manual, Chicago Pneumatic Parts Book, Kubota Engine Manual and Parts book, as well as electronic copies available on request.
- Warranty Registration card for engine and Chicago Pneumatic Compressor (Units must be registered upon receipt).
- Certificate for air/oil separator vessel and safety valve approval, ASME/CRN (Upon request only).

Warranty Coverage

Kubota Engine: Two (2) years / 2,000 hours of operation (whichever occurs first) & Major Component Warranty (MCW) for three (3) years / 3,000 hours (whichever occurs first) warranty from Kubota Engine America. Unit must be registered directly with Kubota upon receipt to be eligible for warranty. Failure to register warranty upon initial startup may cause warranty claim delays or rejection of claim by Kubota.

Chicago Pneumatic Compressor: Warrantied to be free from defects with regard to material and workmanship for the period of eighteen (18) months from date of shipment from the factory, or twelve (12) months from date of initial start-up, whichever occurs first, without limitation of running hours.

Air compressor element assemblies used in Chicago Pneumatic portable air compressors, is warranted to be free from defects with regard to materials and workmanship for the period of thirty (30) months from date of shipment from the factory, or twenty four (24) months from date of initial start up, whichever occurs first, without limitation of running hours. Chicago Pneumatic service kits including parts and oils (GENOil's) must be used to maintain warranty. Failure to register warranty upon initial start-up may cause warranty claim delays or rejection of claims.

Extended Warranty Programs: Programs are available; please contact your local sales representative for more info.

[Q \(/search.aspx\)](/search.aspx)

[\(tel:844-679-5787\)](tel:844-679-5787)

[✉ \(/contactus.aspx\)](/contactus.aspx)



[\(/MyAccount_Orders.asp\)](/MyAccount_Orders.asp)

HOME ([HTTPS://WWW.JIMSLIMSTOOLS.COM](https://www.jimslimstools.com)) :: SHOP BY MANUFACTURER (</DEPARTMENTS/SHOP-BY-MANUFACTURER.ASPX>) :: CHICAGO PNEUMATIC CONSTRUCTION TOOLS (</DEPARTMENTS/SHOP-BY-MANUFACTURER/CHICAGO-PNEUMATIC-CONSTRUCTION-TOOLS.ASPX>) :: AIR TOOLS/PNEUMATIC TOOLS (</DEPARTMENTS/SHOP-BY-MANUFACTURER/CHICAGO-PNEUMATIC-CONSTRUCTION-TOOLS/AIR-TOOLS/PNEUMATIC-TOOLS.ASPX>) :: PAVING BREAKERS - 90LB CLASS - 81CFM @ 90PSI (</DEPARTMENTS/SHOP-BY-MANUFACTURER/CHICAGO-PNEUMATIC-CONSTRUCTION-TOOLS/AIR-TOOLS/PNEUMATIC-TOOLS/PAVING-BREAKERS-90LB-CLASS-81CFM-AT-90PSI.ASPX>) :: CHICAGO PNEUMATIC CP1290 90LB CONCRETE BREAKER 1-1/8IN. X 6IN

Chicago Pneumatic CP1290 90lb Concrete Breaker 1-1/8in. x 6in

[< \(/Products/Chicago-Pneumatic-CP1290-90lb-Concrete-Breaker-1-14in-x-6in__8900003037.aspx\)](/Products/Chicago-Pneumatic-CP1290-90lb-Concrete-Breaker-1-14in-x-6in__8900003037.aspx)

[> \(/Products/Chicago-Pneumatic-CP1290-S-90lb-Silenced-Concrete-Breaker-1-14in-x-6in__8900003039.aspx\)](/Products/Chicago-Pneumatic-CP1290-S-90lb-Silenced-Concrete-Breaker-1-14in-x-6in__8900003039.aspx)

SKU: 8900003038 [Review this product](#)

Like 0

Tweet

Share

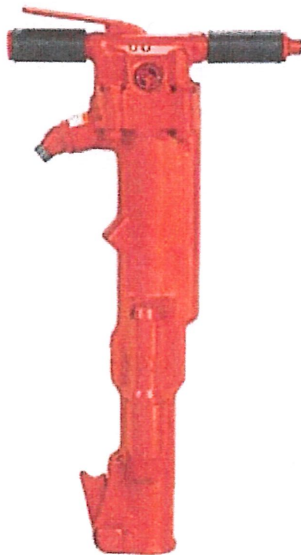

This item normally ships in: **1-3 business days**

List Price

~~\$1,575.00~~

Your Price

\$984.36

You Save \$590.64

Qty

 **Add to Cart**

Add to Wishlist

Applications: Tough construction and plant maintenance work such as breaking reinforced concrete, heavy road work, cutting tarmac, frozen ground or non-consolidated rock and for general demolition work. These new 60-pound and 90-pound breakers continue the tradition of the well-known CP 1230 and CP 1240 with outstanding robustness and reliability in tough working conditions. Plus, they offer more power and are lighter weight.

Key features :

- Even more power and productivity than the CP 1230 and CP 1240
- Improved modern design for excellent durability
- Four-bolt backhead – withstands rugged use
- Integral oiler – provides continuous lubrication
- Reversible piston – reduces maintenance cost
- New swivel design for increased manoeuvrability
- New type of heavy-duty front head springs – reduce maintenance cost
- “Hushed power” versions equipped with mufflers (S-models)
- Versions with improved vibration dampening system (SVR models)

Find Bits Here: <http://www.jimslimstools.com/Departments/Shop-By-Manufacturer/Champion-Chisel-Works/Pneumatic-Pavement-Breaker-Bits/1-18-x-6-Shank.aspx> ([/Departments/Shop-By-Manufacturer/Champion-Chisel-Works/Pneumatic-Pavement-Breaker-Bits/1-18-x-6-Shank.aspx](http://www.jimslimstools.com/Departments/Shop-By-Manufacturer/Champion-Chisel-Works/Pneumatic-Pavement-Breaker-Bits/1-18-x-6-Shank.aspx))

MPN

CP 1290

Write a Review

- ★★★★★ Love It
- ★★★★☆ Like It
- ★★★☆☆ It's OK
- ★★☆☆☆ Don't Like It
- ★☆☆☆☆ Hate It

Review

required

Name

required

Email Address

required

Submit

Customer Reviews

This Item May Require LTL Shipping by a Common Carrier!

Because of the size or or quantity of this item it may need to be shipped by a common carrier on a pallet. This is not usually calculated correctly online.

Contact us for a quote by [email \(mailto:support@jimslimstools.zendesk.com\)](mailto:support@jimslimstools.zendesk.com) for a freight quote. Or continue items to your cart and complete the checkout process. We will contact you with your freight quote for approval before completing your order.

MEMORANDUM

To: Omak City Council
Cindy Gagné, Mayor

From: Todd McDaniel

Date: March 15, 2021

Subject: Ordinance 1903 Amending Budget- Fire Truck

The Attached Ordinance 1903- Amending the 2021 Budget for the City of Omak, Appropriating Funds for Fire Truck Purchase and Recognizing Beginning Fund Balance, is forwarded for your consideration.

This ordinance recognizes an increase in the 2021 Current Expense Beginning Balance (BFB) and appropriates an additional \$96,000 for the purchase of a Fire truck. The BFB balance is better known, now that the 2020 fiscal has ended. BFB IS increased by \$273,752.81, the Fire Truck Expenditure is increased by \$96,000.00, and Ending Fund Balance (EFB) is increased the difference of the additional revenues and Expenditures. \$177,752.81. A \$ -0.01 correction is also included in the EFB to correct rounding errors during budget import.

Committee discussed several options on how to pay for the new Fire Truck. The option of paying cash in advance was selected. This option reduces the purchase price of the Fire truck by \$12,444.00. 2021 EFB remains strong with an end of year amount estimated a \$1,189,808.87.

I approve this Ordinance and urge it Adoption

ORDINANCE No. 1903

AN ORDINANCE AMENDING THE 2021 BUDGET FOR THE CITY OF OMAK BY APPROPRIATING FUNDS FOR FIRE TRUCK PURCHASE AND RECOGNIZING BEGINNING FUND BALANCE

WHEREAS, the City of Omak adopted the 2021 Budget by passage of Ordinance No. 1899 on December 7, 2020; and

WHEREAS, at this time the actual ending fund balance from 2020 and the beginning fund balance for 2021 is better established; and

WHEREAS, the purchase of a fire truck fire truck is desired that exceeds the amount estimate in the 2021 budget; and

WHEREAS, the higher costs of this vehicle was not known or anticipated at the time of adoption for the 2021 budget; and

WHEREAS, it is appropriate to recognize a beginning fund balance for the 2021 budget year that better reflects our actual balance, at this time; and

WHEREAS, said expenditures are not one of the emergencies specifically enumerated in RCW 35A.33.080; and

WHEREAS, the City of Omak is desirous of amending its budget pursuant to RCW 35A.33.090.

THE CITY COUNCIL OF THE CITY OF OMAK DO ORDAIN AS FOLLOWS:

Section 1. Ordinance No. 1899 adopting the 2021 Budget, shall be amended to include changes to the budget as shown in Attachment 'A' of this ordinance.

Section 2. This ordinance shall become effective from and after the date of its passage by Council by a vote of one more than the majority of all Councilmembers, approval by the Mayor and publication as required by law.

PASSED by the City Council of the City of Omak, this _____ day of _____, 2021.

APPROVED:

Cindy Gagne, Mayor

ATTEST:

Connie Thomas, City Clerk

APPROVED AS TO FORM:

Michael Howe, City Attorney

Filed with City Clerk: _____

Passed by City Council:

1ST Reading _____

2nd Reading _____

Date Published: _____

Date Effective: _____

On the _____ day of _____, 2021, the City Council of the City of Omak passed Ordinance No. 1903.

DATED this _____ day of _____, 2021.

Connie Thomas, City Clerk

2021 BUDGET AMENDMENT ORDINANCE NO. 1903 ATTACHMENT 'A'

Description	2021 Budget	Revenue	Expenditure	Revised Budget
<u>Current Expense Fund #001</u>				
Beginning Fund Balance 001.308.80.00.00	\$1,412,245.60	\$273,752.81		\$1,685,998.41
Ending Fund Balance 001.508.80.00.00	\$1,012,056.07	\$177,752.80		\$1,189,808.87
Fire Truck Purchase 001.594.22.64.20	\$ 500,000.00		\$96,000.00	\$ 596,000.00
Total Expenditures	\$4,871,350.72		\$96,000.00	\$4,967,350.72
Current Expense Fund Total	\$5,883,406.79	\$177,752.80	\$96,000.00	\$6,157,159.59

Current Expense Fund:

This appropriation recognizes an increase in the beginning fund balance of \$273,752.81 for the 2021 budget year, authorizes additional expenditure of \$96,000 for the purchase of a fire truck, and increases the Estimated Ending Fund Balance for the 2021 year by \$177,752.80, the balance remaining, after the additional appropriation less 1 cent correction.



INTEROFFICE MEMORANDUM

TO: MAYOR GAGNÉ
OMAK CITY COUNCIL

FROM: CONNIE THOMAS, CITY CLERK 

SUBJECT: ORDINANCE 1904 – OMAK CITY HALL HOURS OF OPERATION

DATE: MARCH 15, 2021

The attached **Ordinance 1904 - AN ORDINANCE AMENDING SECTION 2.68 OF THE OMAK MUNICIPAL CODE RELATING TO DESIGNATED OFFICE HOURS FOR OMAK CITY HALL** is presented to you for your review and consideration.

The City Hall hours of operation open to the public are currently 8am to 5pm, Monday thru Friday. It is desirous to amend the hours of operation open to the public from 7am to 4pm Monday thru Friday. Staff has also reached out to other local government agencies in the Okanogan Valley and found they open earlier than 8am and are closing either at 4pm or 4:30pm. The change in hours would also provide continuity for customers and staff with other departments.

I approve this resolution and respectfully request adoption.

ORDINANCE NO. 1904

**AN ORDINANCE AMENDING SECTION 2.68 OF THE OMAK
MUNICIPAL CODE RELATING TO DESIGNATED
OFFICE HOURS FOR OMAK CITY HALL**

THE CITY COUNCIL OF THE CITY OF OMAK, WASHINGTON, DO ORDAIN as follows:

Section 1. Section 2.68.010 of the Omak Municipal Code providing as follows:

2.68.010 Office hours – designated.

Omak City Hall shall be kept open for the transaction of business with the public from the hours of eight a.m. to five p.m., five days per week, Monday through Friday, except legal holidays as provided and set forth in RCW 1.16.050, as now provided or hereafter amended. All other departments shall maintain office hours as approved by the mayor. Nothing in this provision shall be interpreted as prohibiting temporary closures of City Hall as authorized by the mayor due to emergencies, staff shortages, or other special circumstances.

Is hereby amended to read as follows:

2.68.010 Office hours – designated.

Omak City Hall shall be kept open for the transaction of business with the public from the hours of seven a.m. to four p.m., five days per week, Monday through Friday, except legal holidays as provided and set forth in RCW 1.16.050, as now provided or hereafter amended. All other departments shall maintain office hours as approved by the mayor. Nothing in this provision shall be interpreted as prohibiting temporary closures of City Hall as authorized by the mayor due to emergencies, staff shortages, or other special circumstances.

Section 2. This ordinance shall become effective from and after its passage by the council, approval by the Mayor, and five days after publication of this ordinance, or a summary, as provided by law.

PASSED BY THE CITY COUNCIL this _____ day of March 2021.

APPROVED:

Cindy Gagné, Mayor

ATTEST:

APPROVED AS TO FORM:

Connie Thomas, City Clerk

Michael D. Howe, City Attorney